

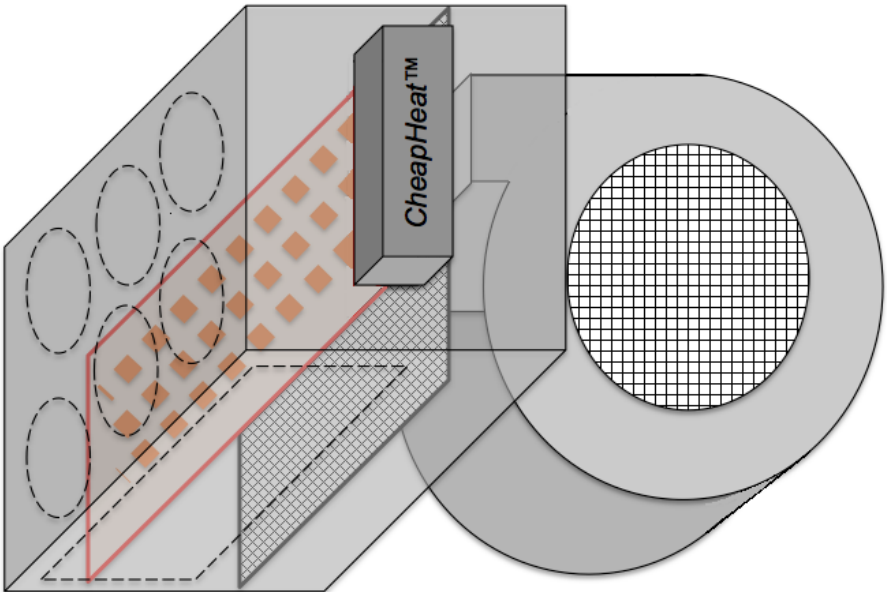

# Installation & Safety Manual

## Stand-A-Lone BL-12 With 12 VDC Blower

This a wire diagram NOT A PICTURE  
Do Not Wire as shown in the diagram.  
Wire according to the TEXT shown on  
each wire.



# RVComfortSystems

[www.rvcomfortsystems.com](http://www.rvcomfortsystems.com)

# CheapHeat™ System

Model# CH-50 & DH18-37-50



**RV Comfort Systems**

PO Box 1554

Bothell, WA 98041

## Installation and Operation Instructions

### READ INSTALLATION INSTRUCTIONS COMPLETELY BEFORE STARTING

Thank you for choosing RV Comfort Systems CheapHeat™ for your heating needs. You can feel confident in your selection of the CheapHeat™ because the same pride in craftsmanship and engineering that goes into other RV Comfort Systems products has been incorporated into the CheapHeat™.

This manual is designed to help with installing, operating and maintaining the unit. It is CRUCIAL that the installation instructions be followed to prevent damage to the CheapHeat™ and existing gas furnace.

Before starting work on any high voltage (120/240V AC) project, turn off power to affected areas. To accomplish this on an RV, shut down all shore power sources, including generators and inverters. In addition, adhere to all U.S. electrical codes.

It is also important that the compatibility applications chart be followed, especially airflow and shore power requirements. To operate the CheapHeat™ efficiently, the installer needs to read this installation manual completely.

Please retain this manual for future reference and send in the warranty card.

### ELECTRICAL DATA

1. All wiring must comply with local and national electrical codes and be installed by a qualified electrician.
2. All wiring/cabling that passes through electrical boxes and panels MUST have cable clamps installed to prevent wire chaffing.
3. Contact a qualified electrician with any questions about the following instructions.
4. Check the available power supply and resolve any wiring problems BEFORE installing or operating this unit.
5. The CheapHeat™ is designed to operate from a 30-amp, 120V AC, 60Hz shore power supply for the DH18 configuration and a 50-amp, 240V AC, 60Hz shore power supply for the DH37 and DH50 configurations.
6. The wiring diagrams and specifications, with respect to wire size, fuse/breaker size and grounding requirements, must be followed. **Note: 12.5% decrease in AC voltage relates to a 25% decrease in Heat output\***
7. Do not immerse in water.
8. To provide continued protection against risk of electric shock, connect to properly grounded outlets only.

### MULTIPLE SYSTEMS IN ONE COACH

1. Setting up multiple systems in one coach requires the following configurations and a separate CH-50 controller for each system.

Shore Power	CheapHeat™ Heater Configurations	Ducting
50 Amp	1-DH18 and 1-DH18	<i>Each system requires its own ducting with no common connections to the other system.</i>
50 Amp	1-DH18 and 1-DH37	
50 Amp	1-DH37 and 1-DH37	

### AIRFLOW REQUIREMENTS (Return/Supply)

1. For systems with an installer-provided adapter cabinet, the DH18 and DH37 configurations require at least 60 square inches of free airflow. The DH50 requires at least 80 square inches and approximately 30-50% additional space for loss caused by louvers.
2. At a minimum, the CheapHeat™ requires the following **free airflow without restrictions**:
  - DH18 – (3) Three 4” round ducts or one 4” x 14” duct with 3 registers
  - DH37 – (5) Five 4” round ducts or one 4” x 14” duct with 4 registers
  - \*DH50 – **(6) Six 4” round ducts** or one 4” X 17 1/2” duct with 5 registers

\*Note: This may require a (6<sup>th</sup>) 4” run be added to provide adequate airflow in some cases.

### OPERATION INSTRUCTIONS

Operating the CheapHeat™ is very simple since there is only one control: the thermostat. The manufacturer-supplied thermostat controls the temperature of the RV, so the only thing the owner needs to do is select a temperature baseline.

To maintain the best comfort-level and reduce temperature hunting (*too hot then too cold*), it is recommended that the RV owner only set the thermostat once for the duration of the heating cycle.

Lastly, to ensure a long system-life and maintain a comfortable environment:

1. Minimum unrestricted airflows must be compliant with the compatibility chart and
2. The RV must be hooked up to the manufacturer-recommended shore power connections when using the CheapHeat™ without adapters.

### CONTROLLER

The CheapHeat™ CH-50 controller has been designed to work with all CheapHeat™ electric elements and Stand-A-Lone cabinet. The only time changes required within the controller are when it is used with the 12 VDC Blower with the DH18-120 electric coils. In that configuration you can move the fan speed jumpers to change the fan speed to match the heating capacity.

The CheapHeat™ controller casing needs to be able to dissipate heat that is generated by its internal components. ***It does not get anywhere close to hot enough to cause a fire hazard.*** DO NOT mount the CheapHeat™ controller on the Stand-A-Lone cabinet or connecting ductwork.

### ELECTRIC HEATER COIL

There are three electric heating capacities even though there is only one heater coil. This is because the coil was designed in a multi-tap configuration (two voltages and three heating outputs), which helps dealers reduce inventories and control costs. The most important thing to remember when installing the heater is that the heater assembly should be installed so that the

FUSIBLE LINK (*looks like a diode*) is physically located on the bottom of the heater assembly.

## STAND-A-LONE CABINET

### Clearance from Combustibles

Top-----	1”
Side w/ Heater Head -----	3” To allow clearance for electrical access
Side w/o Heater Head-----	1”
Front w/ 4” Duct-----	6” To allow connection of 4” round ducts
Front w/o Duct-----	1”
Bottom-----	0”

RV manufacturers install forced-air heating systems in one of two configurations: ducted system with individual duct runs or plenum system with trunk lines and registers in the floor. This means the CheapHeat™ installer needs to choose the correct Stand-A-Lone cabinet configuration and be mindful that the configuration selected has enough clearance around it to connect to the RV ductwork.

Both ducted and plenum system cabinet configurations have been manufactured so the electric heating element can be installed from either side of the cabinet. ***The DH-18 and DH37 Heater requires a minimum 60 square inch free air trunk line and the DH50 adapter requires a minimum 80 square inch free air trunk line feeding directly off of the cabinet.***

### Tools Required

- AC/DC Volt-Ohm-Amp Meter
- Wire Stripers and Crimpers
- Wire Cutters
- 3/8” Drive Drill Motor
- Sheet Metal Snips
- 3/4” Wood Bit
- 1/2” Wood Bit
- 1/4” Drill Bit
- 3/16” Drill Bit
- 1/8” Drill Bit
- 1/4” Nut Driver
- 5/16” Nut Driver
- 1/4” Hex Nut Drive Drill Bit
- #2 Flat / #2 Philips Screwdriver Bits
- 6 1/8” Square Head Screwdriver
- 6” Flat Blade Screwdriver
- 6” Philips Screwdriver
- 3/4” Black Electrical Tape
- 2” Wide 3M High Temperature Metal Tape

## PARTS

Remove controller, electric heater coil and cabinet from packaging. Verify that all parts are present, in good condition and correct for this installation.



## Materials Not included in CheapHeat Kit

### Electrical:

- **2 Pole Breaker Sub Panel**  
(Home Depot: Store SKU #376330)
- **2 Pole 30-amp Breaker**  
(Home Depot: Store SO SKU #1000498103)
- **15 Ft 10-3 with ground Romex wire**  
(Home Depot: Store SKU #579406)
- **5 Pac ¾" Romex Cable Clamps**  
(Home Depot: Store SKU #279782)

### Misc. Materials:

- **Metal Tape UL Listed 1.89" x 30 Ft**  
(Home Depot: Store SKU #1002164176)
- **6 - 4" hose clamps**  
(Home Depot: Store SKU #1000052166)

### Additional Ducting: *(if needed)*

#### Adding only one Duct

- 20 Ft - 4" Flex Duct/Dryer vent hose  
(Home Depot: Store SKU #1000052093)

#### Adding second Duct

- 4" Round Wall register  
(Amazon:  
[https://www.amazon.com/dp/B07GVS9V71/ref=psdc\\_13400071\\_t3\\_B078TJN7WX](https://www.amazon.com/dp/B07GVS9V71/ref=psdc_13400071_t3_B078TJN7WX))

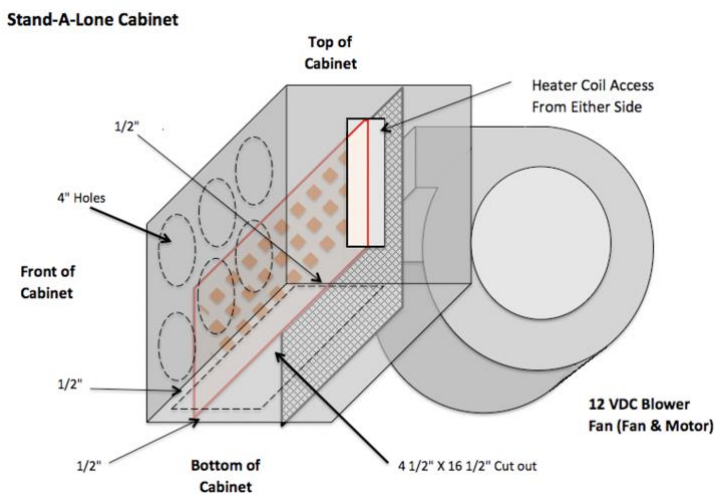

Any additional questions contact Larry @ RV Comfort Systems Phone: 425-408-3140

**RVComfortSystems LLC.**

[www.rvcomfortsystems.com](http://www.rvcomfortsystems.com)

## Package #1

### Parts Included

- 1 – **CheapHeat™ Controller**
- 3 – Orange Wire Nuts
- 2 – Red Wire Nuts
- 8 – 6" Nylon Wire Ties
- 2 – 8 x 1/2" Philips Oval Head Taper Point Screws (For Securing Controller to Wall)
- 4 – 8 x 3/4" 1/4" Hex Drive Mounting Screws (For Securing Add-On Cabinet to Furnace)
- 4 – 6 x 3/8" 1/4" Hex Drive Mounting Screws (For Electric Element and Panels)
- 2 – 1/2" Romex Cable Clamps
- 1 – 3/4" Romex Cable Clamp

### **Electric Element**

- 1 – Electric Heater Element (Model DH18-37-50 Works for All Configurations)

## Package #2

### Parts Included

- 1 – Stand-A-Lone Cabinet
- 1 – Blank Plate Cover for Heater Compartment

### Optional

- 6 – 4" Starter Collars for Flex Duct.

## Package #3

### Parts Included

- 1 – 12 VDC Blower with Motor
- 1 – 2 X 2 X 4 Box Extender
- 1 – 2 x 2 x 4 Blank Plate
- 1 – 120/240 VAC to 12 VDC (1.5 Amp) plug-in adapter (Only for RV's without 12 VDC Power)

## SITE PREPARATION

- Make sure all high voltage to the RV is disconnected.
- Check installation area to see that it meets all clearance requirements necessary to complete CheapHeat™ installation.
- Identify and mark wires from fuse panel.
- Make sure there is a 120 VAC wall receptacle within 4 feet of controller for 12 VDC adapter (Only for RV's without 12 VDC power)

## MOUNTING COMPONENTS

### Controller

- Find an accessible location within 10' of Stand-A-Lone Cabinet and mount controller with 4 – 8 x 3/4" screws provided. Do not mount controller on the Cabinet or its associated ductwork.

### Thermostat

- When picking a location for the thermostat, remember: it needs to be located inside the coach, in a place easily accessible by the owner out of direct sunlight, on an inside wall and approximately 60" off the floor. NOTE: Low voltage provided to thermostat from the controller is 12 VDC max 1.0 amps.

### Breaker/Disconnect

Heater Configuration	Wire Size	Breaker/Fuse Size
DH18-120	12 Ga.	20 Amp Single
DH37-240	12 Ga.	20 Amp Double
DH50-240	10 Ga.	30 Amp Double

# Stand-A-Lone Cabinet

**Blower and Motor:** Prior to installing cabinet and connecting ductwork, slide the blower and motor in to place and lock in place with 3/4 X 8 sheet metal screw. (See Figure 1). After attaching blower to cabinet, seal blower flange to cabinet with 3M 300 degree F metallic tape.

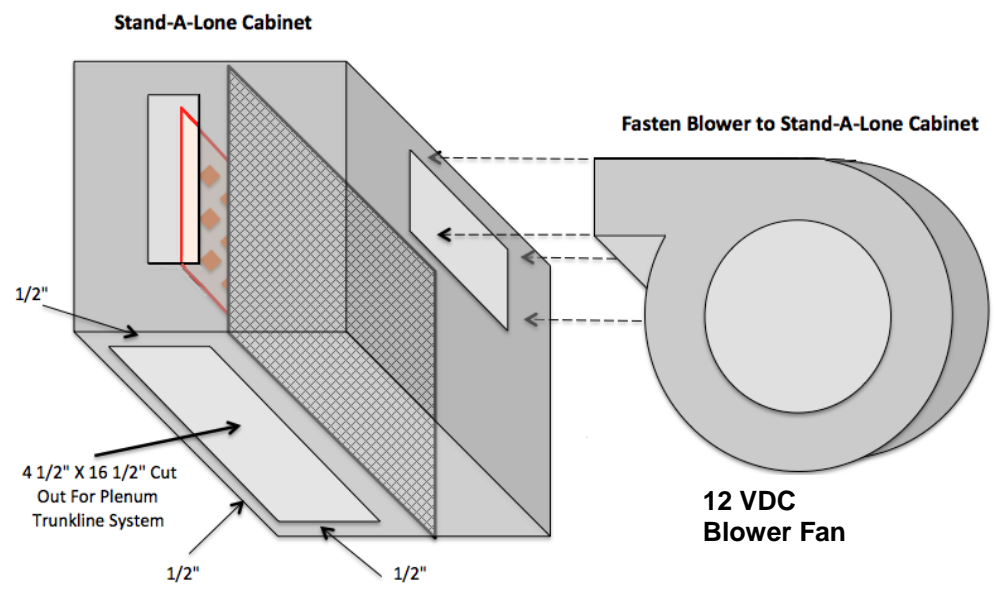
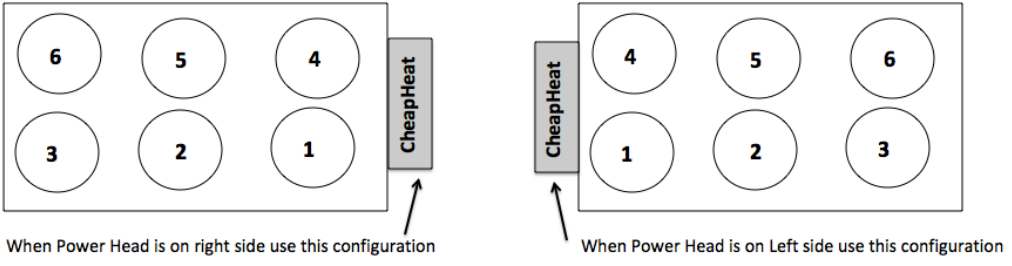

Figure 1

**Ducted System:** Prior to installing the new cabinet, count the current number of 4" duct runs supplied. Before installing the electric heater coil, drill the same amount of 4" holes (see figure 2 to determine correct location of holes) and install the starter collars (figure 2) in the cabinet as described below.

When adding Ducts on Ducting only System add 4 Inch Ducts to Cabinet front in numerical order as shown



When adding 4 inch Ducts on Combination Plenum/Ducted System add 4 inch Ducts in numerical order as shown

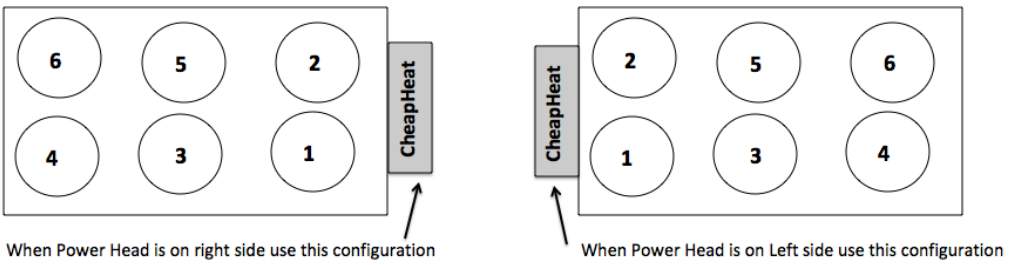

Figure 2



Figure 3



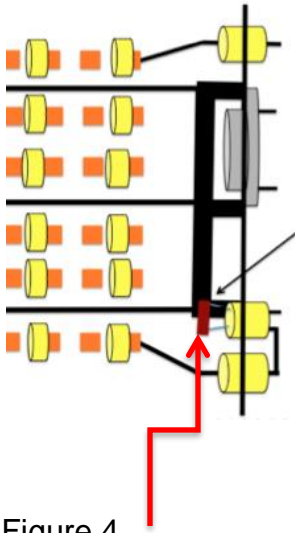

Figure 4

Fusible Link looks like a diode and should ALWAYS be located at the bottom of the coil when the heater is installed.

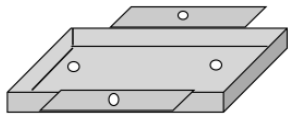

Figure 5

1. Bend all but 3 tabs 20 degrees in toward center of collar (see figure 3 on previous page).
2. Bend the 3 unbent tabs back 90 degrees (figure 3).
3. Insert tab side of collar in previously drilled 4" hole in add-on cabinet.
4. Bend out the tabs (away from center of the collar) back up inside the cabinet face locking the collar in place.
5. Slide electric heater element into cabinet (***making sure that the FUSIBLE LINK is located at the bottom of the heater coil***) and fasten using 2 – 6 x 3/8" screws (see figure 4). Before installing element into cabinet, make sure to pick the side that will allow the easiest access to the electrical connections after the add-on cabinet is connected to the gas furnace.
6. Install blank plate using 2 – 6 x 3/8" screws on the add-on cabinet opposite the opening that the electric element was installed in. Make sure that the electric element support rod fits through the hole in the blank plate (figures 5 and 6).
7. Connect 4" flex duct (with the old 4" hose clamps) to cabinet starter collars, which were previously installed in cabinet.

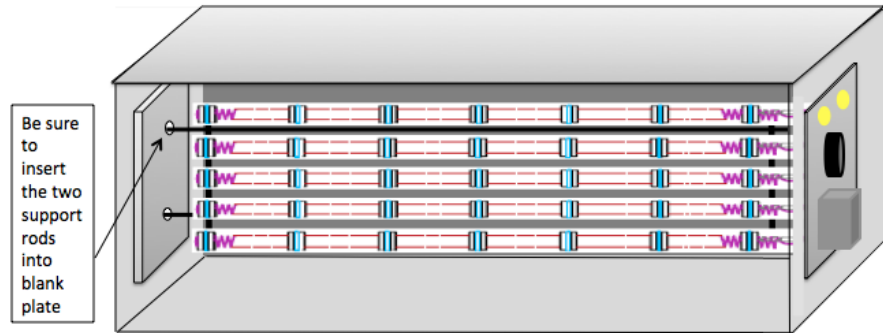

Figure 6

**Plenum System:** The plenum stand-a-lone cabinet is the same cabinet that is used with the ducted system except in this configuration the air is discharged out the bottom of the cabinet as shown in (figure 6).

**Stand-A-Lone Cabinet**

Before starting the installation process for the plenum system configuration, cut out 4½" x 16½" as shown in (figure 7). In addition, make sure that there is clear access through the floor to the trunk line under the plywood with no structural cross supports.

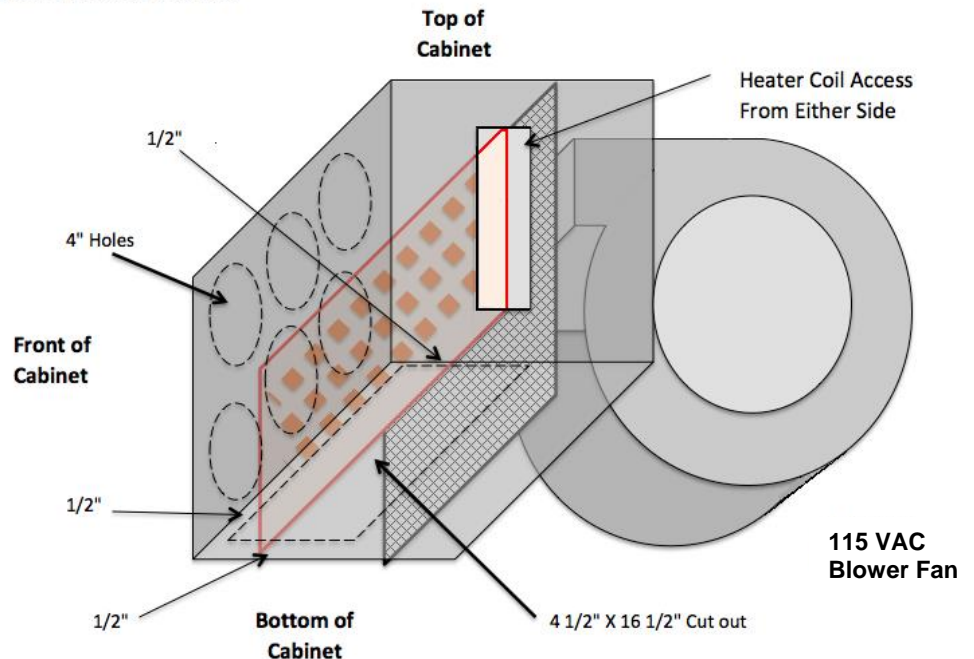

Figure 7



1. Measure a 4  $\frac{3}{4}$ " X 16  $\frac{3}{4}$ " section on the floor that aligns with the opening in the bottom of the Stand-A-Lone Cabinet and a hole in floor to access furnace plenum (see figure 8).
2. Cut an opening in the exposed duct under the floor to match the opening and seal duct to new opening in floor with 300 degree F 3M metallic tape.
3. Before installing cabinet, make sure to install the electric element (see figure 6) and blank plate in the cabinet using the 6 x 3/8" sheet metal screws to secure in place. *Be sure to install element so that electrical access is possible after the elbow is installed.*
4. Install the cabinet over the newly cut hole and seal duct to new opening in floor by adhering 300 F degree 3M metallic tape to the bottom of the cabinet.

**Register Free Air**

2 1/2" X 12" Floor Registers equal 12 Sq In Free Air because of Lovers  
 4 X 10" Floor Registers equal 20 Sq In Free Air because of lovers

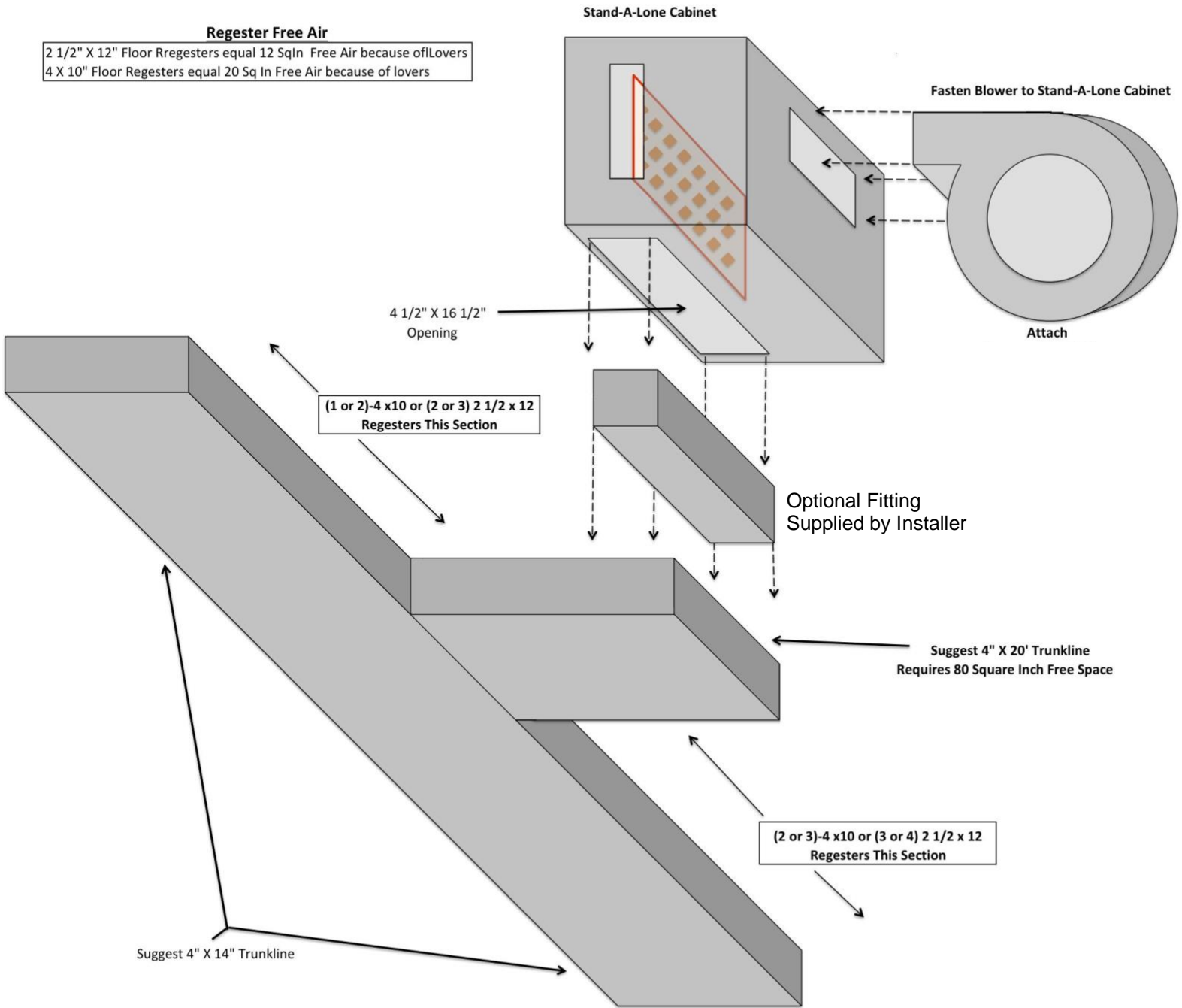

Figure 8

**WIRING SYSTEM:** All high voltage wiring should be 300 V NEMA rated and meet all national, state and local electrical codes. All wiring/cabling that passes through electrical boxes and panels **MUST** have cable clamps installed to prevent wire chaffing.

**Disconnect Wiring**

**NEC (National Electrical Code) “10-foot rule”**  
 In accordance with the NEC (National Electric Code) it is acceptable to have the same gauge (size) of wire FEEDING a fused Disconnect as the wire LEAVING the Disconnect as long as (See *Wire Size Chart Below*):

1. That wire is large enough to handle the size of the circuit ampacity protection inside that disconnect.
2. The feed in wire is **NO LONGER** than **10 feet**.
3. As long as the fused rating of the disconnect is in excess of 10% of the total feeder ampacity line it is attaching to.

FOR ANY ADDITIONAL QUESTIONS SEE THE ATTACHED EXCERPT (last pages of installation manual) FROM THE NATIONAL ELECTRICAL CODE BOOK Section 240.21 (B)(1).

**High Voltage Wire Size Chart**

Elect Heater Configuration	Disconnect to Shore Power (10-ft. rule)	Disconnect to Controller	Controller to Heater Element
DH18-120	12 Ga.	12 Ga.	12 Ga.
DH37-240	12 Ga.	12 Ga.	12 Ga.
DH50-240	10 Ga.	10 Ga.	10 Ga.

**Shore Power Socket Guide**

50 Amp	30 Amp	Voltage
Red to Black		230
Red to White		115
Red to Green		115
Black to White	Black to White	115
Black to Green	Black to Green	115
White to Green	White to Green	115

When connecting to shore power polarity is very important be sure to **follow the color code** of the wires the Factory has hooked up when they installed the shore power wires to the socket and transfer switch.

## High Voltage Wiring:

When running wire from disconnect/breaker make sure to follow the color code as shown below in figure 9.

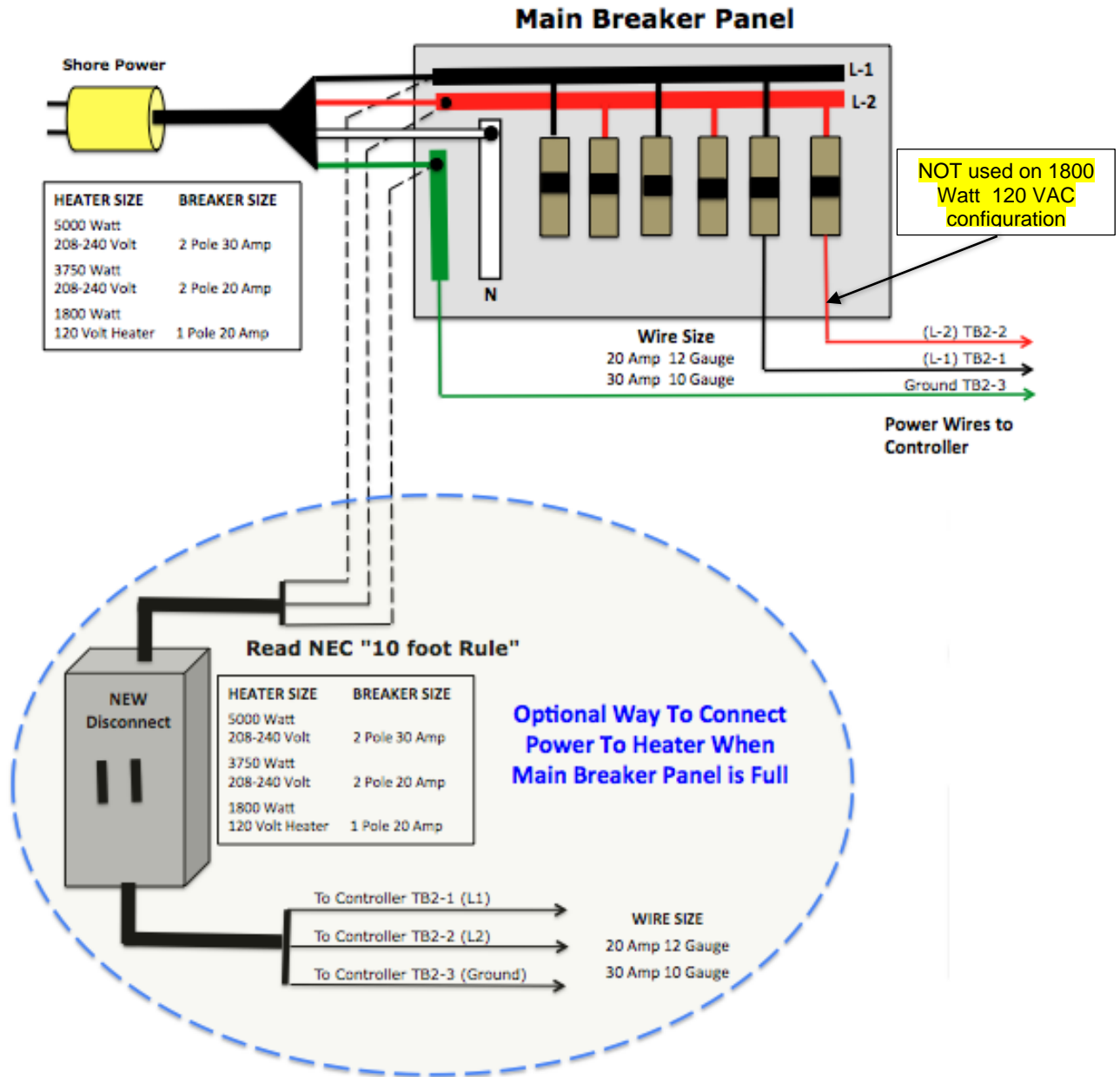

Figure 9

1. Double-check all connections to make sure that they are tight and connected correctly: Disconnect/Breaker L1 to Controller TB2-L1, Disconnect L2 to Controller TB2-L2 and Disconnect/Breaker ground to TB2-3 Controller.

## Electric Heater Element Wiring: (see high voltage wire size chart)

There are three different heater elements ratings and only one physical coil. Despite that, it is the heater element heat rating that determines the wire size.

1. Run Romex wire between controller and electric heater element located in the cabinet (see figure 10). **Make sure to install cable clamp into 1/2" knockout hole on heater panel to prevent wire from chaffing.**
2. Connect wires from controller TB2 terminal 4 to element ground (**NOT NEUTRAL**), TB2 terminal 5 to element L1 (**COMMON**), and TB2 terminal 6 to element L2 (see Electric Heater Diagram).
3. **DO NOT WIRE 230 VAC TO 1800 WATT ELEMENT**
4. Check all connections for proper tightness and support to prevent chaffing.

The Neutral wire is NOT USED when connecting the 3750 & 5000 Watt 240 VAC heater configuration, it is only used with the 1800 Watt 120 VAC

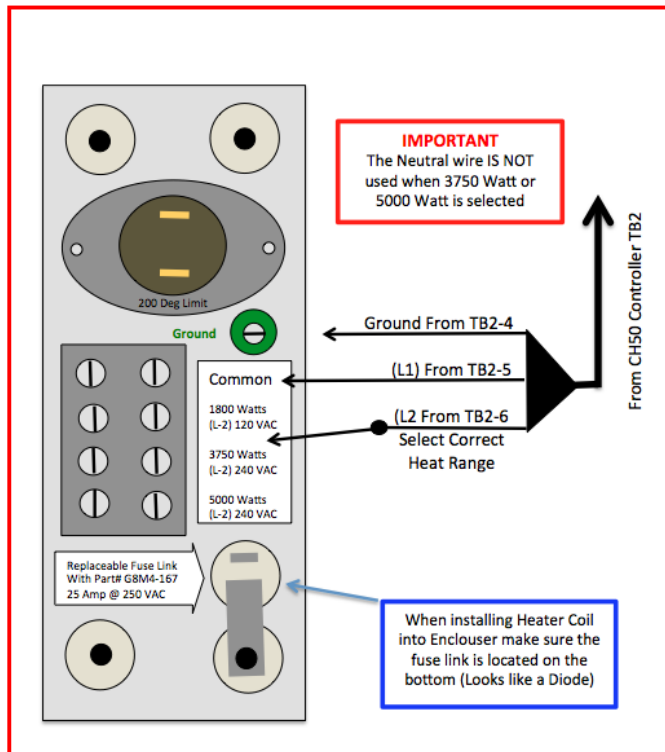

Electric Heater Diagram

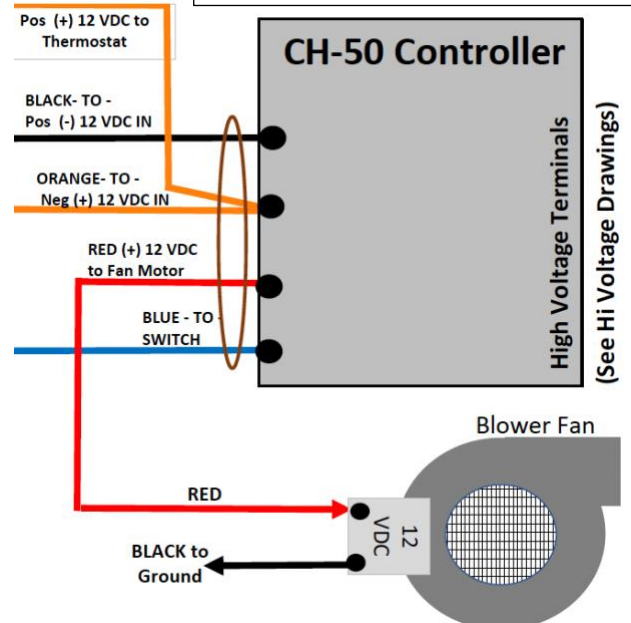

This a wire diagram NOT A PICTURE  
Do Not Wire as shown in the diagram.  
Wire according to the TEXT shown on each wire.

Figure 10  
12 VDC Wire Connection

(See page 15 for complete wire diagram)

## Blower Wiring:

By this time the blower should already be installed on to the Heater Cabinet.

1. Install 2 x 2 x 4 extender box on to Blower as shown in **Figure 11** (make sure that box does not touch motor bracket or vibrations may transmit through cabinet).
2. Install 1/2" chase nipple into side of new electrical box and feed capacitor and motor wires into box as shown in **Figure 12**.
3. Install 1/2" Romex cable clamp into side of junction box and feed 14 Ga. **Red & Black** Low voltage wires from (Customer provided) from junction box to CH50 controller.
4. Connect Fan Motor wires from Blower Junction box to Ground and Terminals 3 (red wire) on TB1 in Controller (**Figure 12**).
5. Install blank plate onto Junction Box.

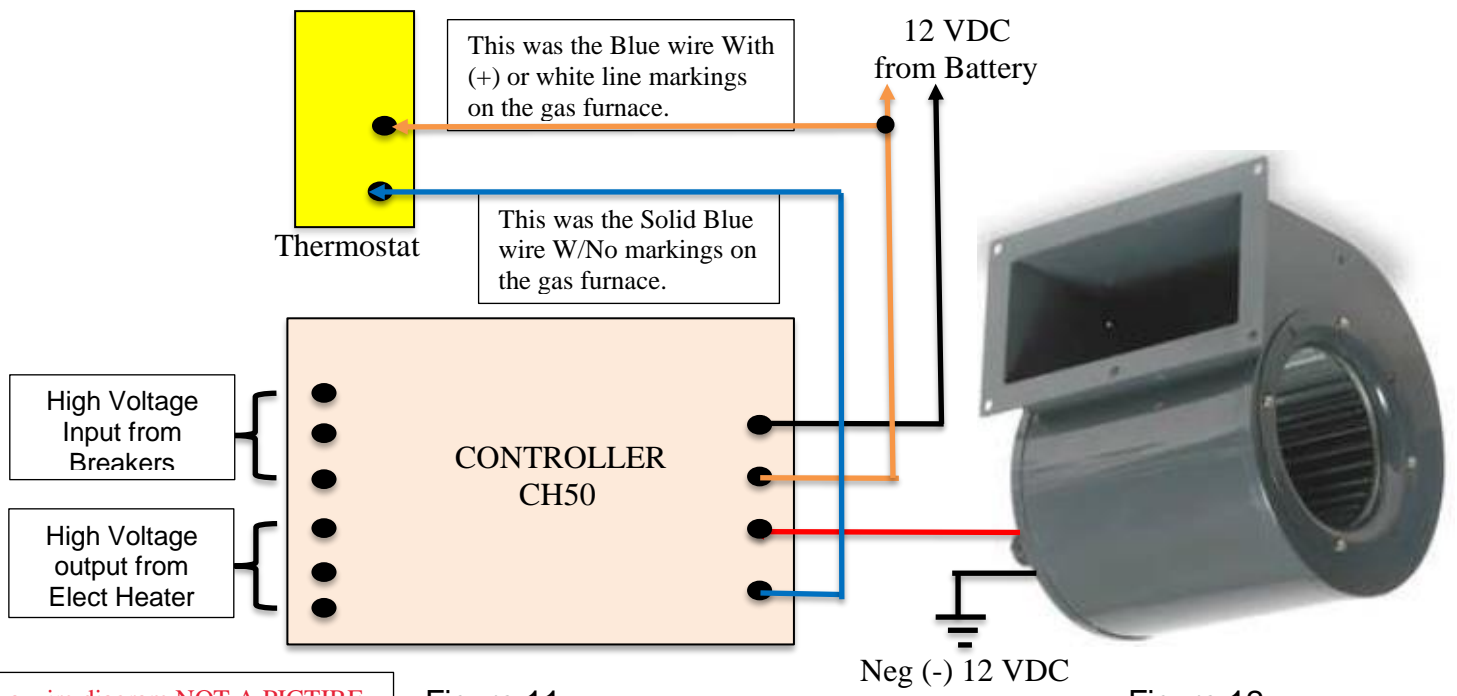

Figure 11

Figure 12

This a wire diagram NOT A PICTURE  
Do Not Wire as shown in the diagram.  
Wire according to the TEXT shown on  
each wire.

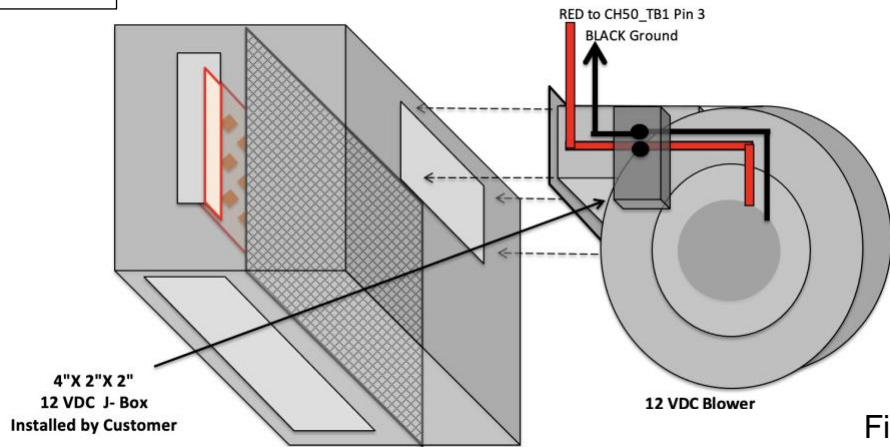

Figure 13

**Controller Wiring:**

The controller has both low (12 V DC) and high voltage (120/240 V AC) running inside its cabinet, so make sure that all power is turned off before starting working on the controller. The high voltage terminal block is marked TB2, and the low voltage terminal block is marked TB1. Ensure that the correct wires are connected to the correct terminal blocks (see figure 11).

**Controller Wiring Chart**

Wire Connected <i>Low Voltage</i>	<b>TB1</b> Term #	Wire connected <i>High Voltage</i>	<b>TB2</b> Term #
NEG (-) 12 V DC From Plug-in Adapter ( <b>Black</b> )	1	(L1) input from Disconnect	1
POS (+) 12 V DC From Plug-in Adapter ( <b>ORANGE</b> )	2	(L2) input from Disconnect	2
Pos (+) 12 VDC OUT to Blower Fan ( <b>RED</b> )	3	(Ground) feed from Disconnect	3
POS (+) 12 V DC from thermostat ( <b>Blue</b> )	4	(Ground) output to Heater	4
		(L1) output to Electric Element	5
		(L2) output to Electric Element	6



By this time in the installation, the high voltage wires should have already been run, so take a minute to confirm that the correct high voltage wires are connected to the correct terminal block (TB2) and the correct terminals as shown in the controller wiring chart above. Then, follow the steps below to connect the low voltage wiring.

### Controller Low Voltage (Optional Power supply)

\*\*\*When the controller requires option 12 VDC power supply due to no 12 VDC being available for the control circuits you must use a 120 or 240 VAC blower motor\*\*\*

Remove the plug-in 120 VAC to 12 VDC adapter from the package.

1. Install ½” chase nipple in to low voltage side of Controller.
2. Connect the **BLACK** wire from Optional Power Supply or RV Converter to TB1-1
3. Connect the (+) 12 VDC Power Supply wire or RV Converter Positive wire to TB1-2
4. Connect the **RED** thermostat wire to TB1-2 and the other end of the wire to the “R” terminal on the thermostat.
5. TB1-3 is **not used**.
6. Connect **BLUE** thermostat wire to TB1-4 and the other end to t “W” terminal on the thermostat.

Thermostat

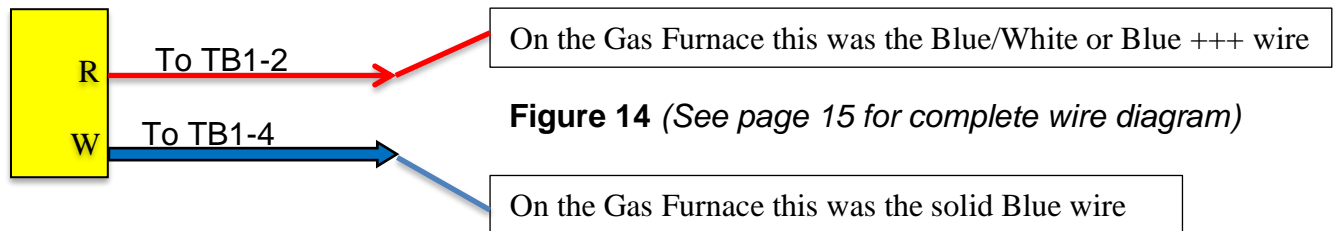

### Run Test

Before starting the run test, make sure that the shore power is turned on and proceed with the following checks.

1. Turn the thermostat to at least 10° F below the RV inside temperature.
  2. Replace the 12 V DC fuse or plug in optional Power Supply
  3. With a voltmeter, confirm 12 V DC at the Controller.
  4. Turn the thermostat up to 10° F above the RV inside temperature (the fan should start immediately).
    - If fan starts correctly, go to step 5, if not continue with this step below.
    - Confirm you have 12 VDC from TB-1 pins 1 & 2 (Confirms main battery power to Controller).
    - Check the that you have 12 VDC at TB1 pins 1 & 4 (this confirms signal from thermostat).
    - Check to see if you have 12 VDC from TB-1 pins 2 & 3 (confirms controller working).
    - Test for 12 VDC at the connection of where the RED wire from the controller is attached to the RED blower motor wire. (confirms good wire run).
    - Repeat step 4
  5. Turn the thermostat back down 10° F below RV inside temperature (the fan should stop immediately).
    - If the fan does not shut off immediately, check wiring at pins TB1- 1 and 4 to see you have 0 VDC.
    - Repeat step 5.
    - If fan shuts off correctly, go to step 6.
  6. Make sure that the thermostat is set 10° F below RV inside temperature.
  7. Remove the access panel to the controller, and check the voltage on TB2 pins 1 and 2.
    - If hooked to a 30-amp shore power system, the reading should be 115 V AC.
    - If hooked to a 50-amp shore power system, the reading should be 230 V AC.
- If these readings are not correct, fix the problem before continuing.

8. Remove the access panel for the electric heating element.
9. Attach amp probe meter around **one of the wires** hooked to the heater.
10. Turn thermostat up 10° F above RV indoor temperature and read amp reading at electric heater (see chart below for correct readings).
11. Verify that there is heat coming out of all of the registers in the RV.
12. Let system run for at least 20 minutes to make sure that there are no problems.
13. If the system runs with no drop in current for the full 20 minutes go to step 15.
  - During that time watch the amp meter to make SURE it does not drop to 0 amps at any time during this test.
  - if it drops you have an Air flow problem which may be one of three things:
    1. Not enough duct work
    2. Duct work leaking hot air back to the furnace
    3. Fan motor that has a low voltage or bad bearings.
14. Repair problems and repeat step 12.
15. Turn thermostat back down to 10° F below RV indoor temperature.
16. Remove amp probe, and reinstall electric heater access panel.
17. Turn thermostat off, replace all panels and inspect wiring.
18. YOU ARE DONE. GOOD JOB!

## Troubleshooting

This system is pretty straightforward. If you have any problems, redoing the RUN TEST section should help resolve any problems except for defective parts. The schematic shown below should help you resolve any diagnostic problems.

**12 VDC Blower**  
 LOW VOLTAGE WIRE DIAGRAM FOR **STAND-A-LONE** 12 VDC Blower

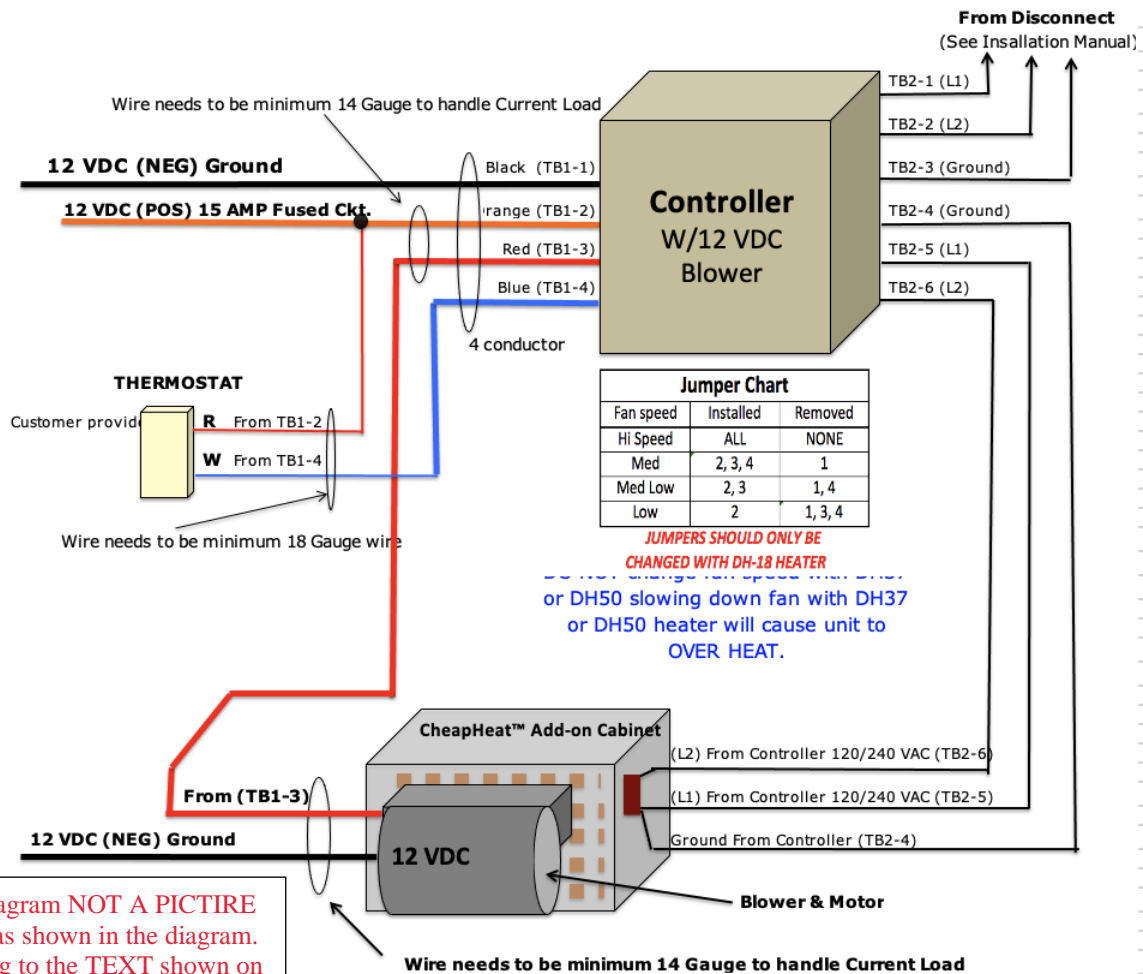

This a wire diagram NOT A PICTURE  
 Do Not Wire as shown in the diagram.  
 Wire according to the TEXT shown on  
 each wire.



# RVComfortSystems LLC.

www.rvcomfortsystems.com

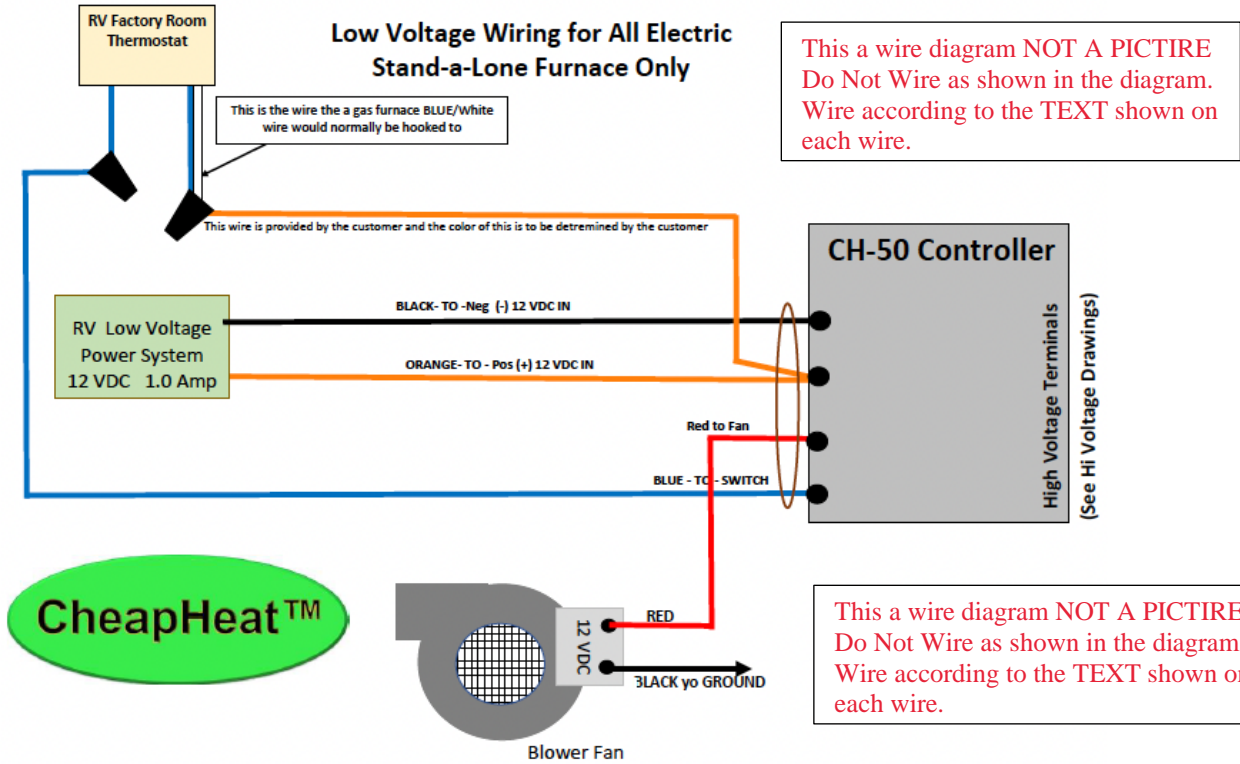

Picture above shows low voltage furnace wiring With the CheapHeat All Electric Furnace

## High Voltage Wiring for All Electric Furnace

**CheapHeat™**

# RVComfortSystems

www.rvcomfortsystems.com

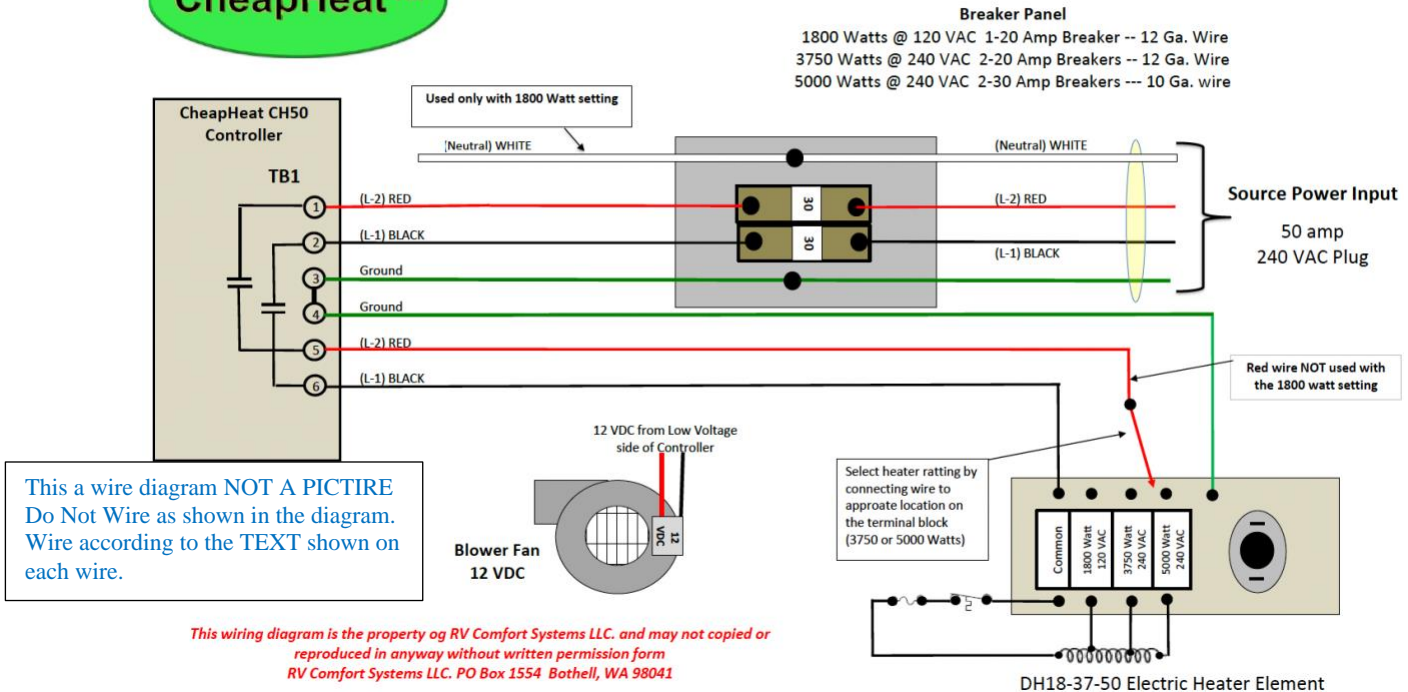

# High Voltage Wiring for Dual Voltage System

Wire color codes and wiring to terminals must be followed EXACTLY as shown.

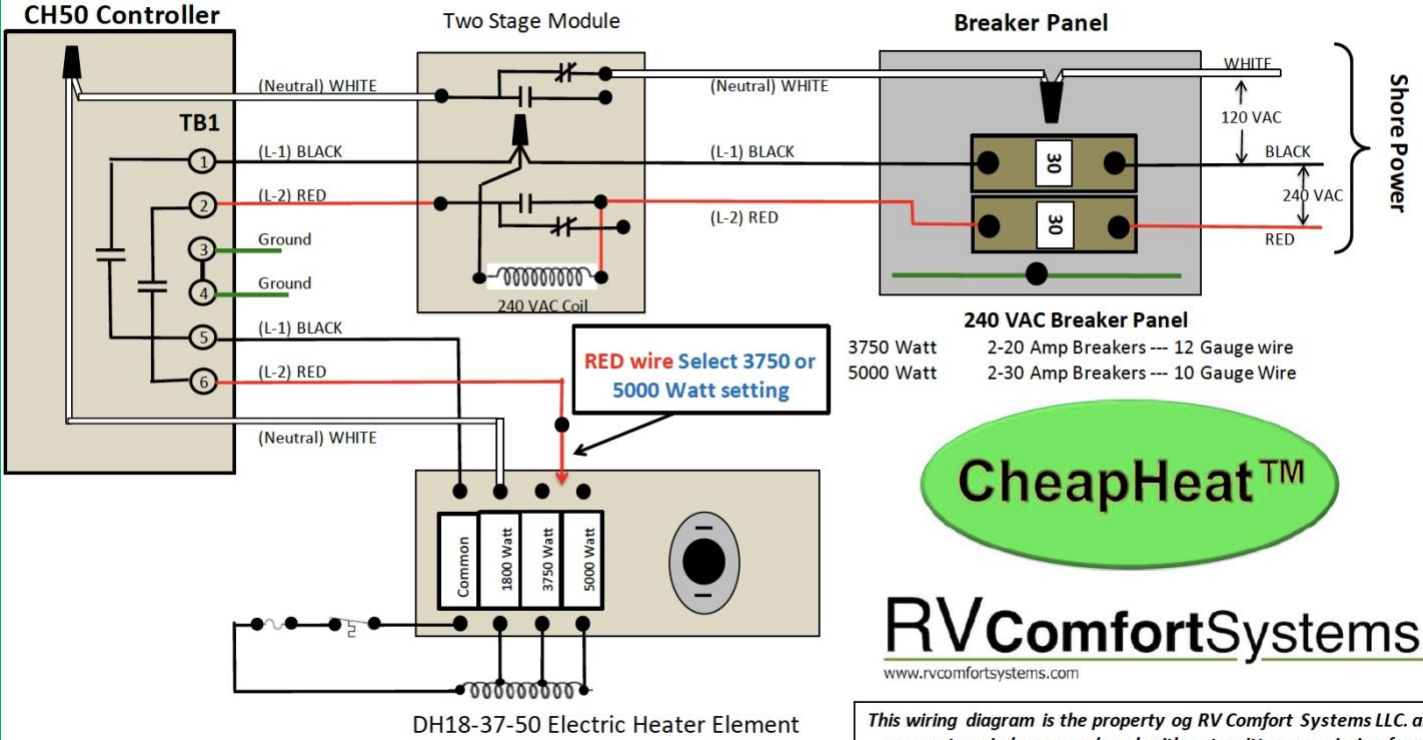

**RVComfortSystems**  
www.rvcomfortsystems.com

This wiring diagram is the property of RV Comfort Systems LLC. and may not copied or reproduced with out written permission form RV Comfort Systems LLC. PO Box 1554 Bothell, WA 98041

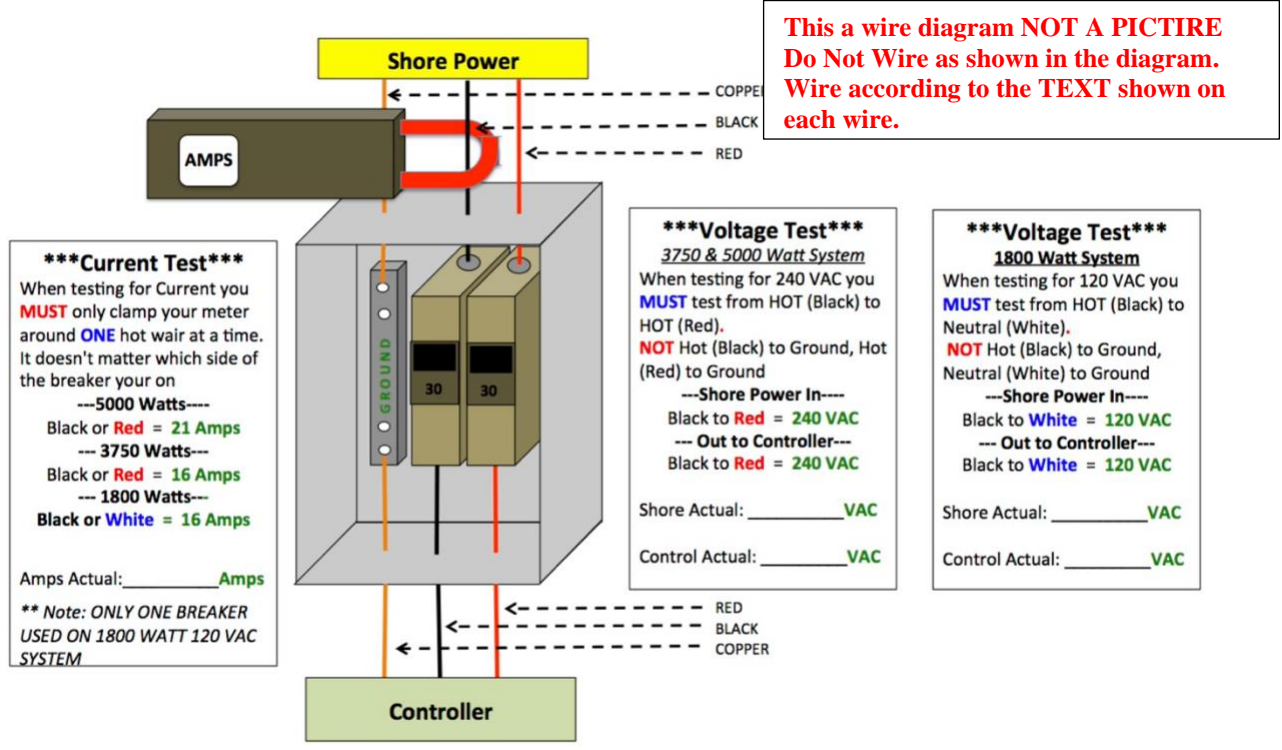

**READ THE \*\*TEXT ON THE CONTROLLER PCB & HEATER\*\* BEFORE YOU WIRE SYSTEM**

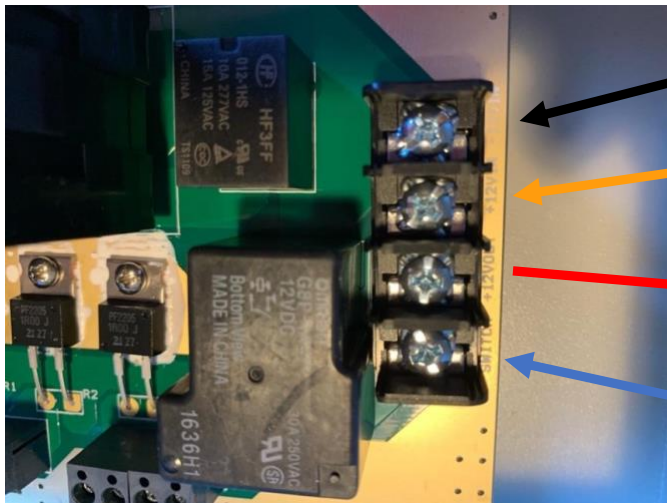

<b>BLACK</b>	Neg (-) 12 VDC from RV
<b>ORANGE</b>	Pos (+) 12 VDC from RV **For Stand-A-Lone All Electric only Additional feeder wire from this (+) 12 VDC Pos terminal to the input to the thermostat.
<b>RED</b>	<b>RED</b> wire directly to <b>RED</b> wire of 12 VDC blower motor at Blower motor
<b>BLUE</b>	Switch Leg from Override Switch WHITE wire (Hybrid System). ***From thermostat directly on (Stand-a lone System).

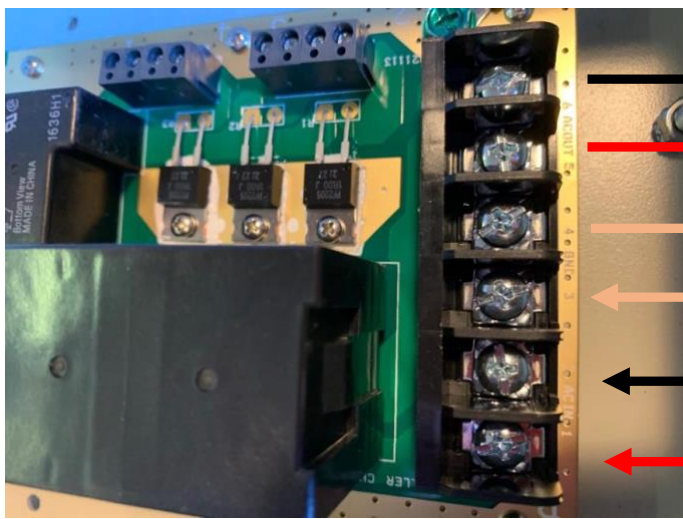

<b>Black L-1 Out</b>	to Common terminal on Heater (all heater ranges). <b><u>THIS IS NOT A WHITE NEUTRAL WIRE EVER.</u></b>
<b>RED L-2 Out</b>	to 3750 or 5000 Watt terminal on Heater. Not used with the 1800 Watt setting
<b>Green</b>	out to Heater
<b>Green</b>	from Breaker Panel
<b>Black L-1 IN</b>	from Breaker (all heater ranges).
<b>RED L-2 IN</b>	from Breaker when setting for 3750 or 5000 Watts. ** When 1800 watt heater range use WHITE wire just passes through Controller and does not connect to anything in controller. With the 1800 W setting the RED is not used

**\*\*\*SPECIAL NOTES FAN\*\*\***  
Stand-A-Lone ONLY All Electric furnace 120 VAC fan has two BLACK wires. One connects to the BLACK out on the controller and the other BLACK connects to the WHITE coming from the Breaker Panel

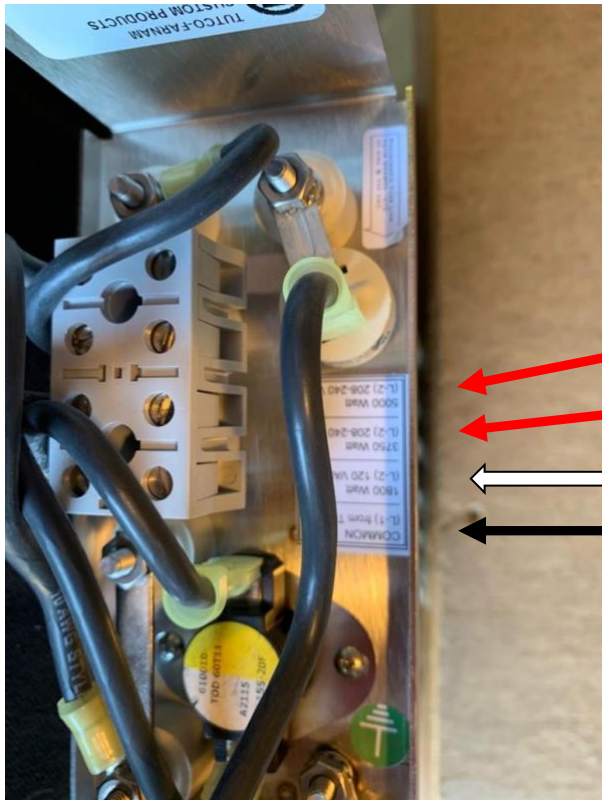

<b>RED L-2 IN</b>	from Controller AC-Out terminal when 5000 Watt range used..
<b>RED L-2 IN</b>	from Controller AC-Out terminal when 3750 Watt range used..
<b>WHITE</b>	from Controller Neutral wire when using the 1800 Watt range only.
<b>Black L-1 IN</b>	from Controller AC-Out Terminal (all heater ranges) <b><u>NEVER WHITE WIRE</u></b>

**\*\*\*SPECIAL NOTES BREAKERS\*\*\***  
5000 Watts requires 10 Ga. wire with two 30 amp breakers  
3750 Watts requires 12 Ga. wire with two 20 amp breakers  
1800 Watts requires 12 Ga. wire with one 20 amp breaker



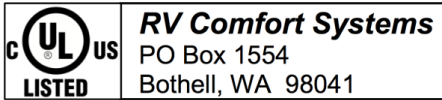

# 20 Minute Test For

## Low Heat Output/Short Cycling

*This assumes the heater is set on the correct heater range*

### Short Cycle Test

This is a simple test that verifies if your ducting system has adequate air flow to prevent your Heater Coil from short cycling, ultimately causing a reduced heat output (*Fan will continue to run even if the heater coil is cycling on over temp*).

- Turn your thermostat up to 82 F degrees and clamp your **Amp Meter around only one** of the high voltage wires coming out of the breakers, that feed the CheapHeat Controller.
- Note current reading, reading should be as follows:
  - 1800 Watt setting = 14.5 to 15 amps @ 120 VAC
  - 3750 Watt setting = 14.5 to 15 amps @ 240 VAC
  - 5000 Watts setting = 19.5 to 20 amps @ 240 VAC
- During this test you need to watch the amp meter for a full 20 minutes to make sure that the current reading stays constant (*you may need to open the windows and door to keep the thermostat from shutting off during this test*).
- If at any time during this test while the thermostat is calling for heat the meter reading drops out. That is an indication that you have an airflow related problem causing the system to short cycle, which will result in substantial loss in heating capacity.

**Note:**

1. Make sure all of the outside storage compartment doors are closed. This is to make sure the furnace it NOT sucking in outside air, which will through off the test.
2. Be sure you have the correct voltage coming out of the breakers that feed the controller. If you have 120 VAC Test Black to White, if you have 240 VAC. Test Red to Black (*Testing one lead to ground will not give you the correct reading*).

### Possible cause of Short cycling

1. Duct work related problem:
  - Check ductwork for holes, leaks, blockages or tears.
    - Torn or leaking ductwork will allow hot air to short cycle back through the return air causing the high temp safety switch to short cycle reducing the output temperature.
    - Blockage in duct work or not enough duct work will cause a reduced air flow across the heater coil causing in a high temperature short cycle by the high temp safety switch, resulting in a lower output temperature of the overall system.
2. Not enough ductwork:
  - Ductwork minimums specs must be follow as shown in the installation manual (**Spec's shown below**).
    - The CheapHeat system is a UL listed device we are have safeties in place that will not allow any part of our ductwork to exceed very specific surface temperatures. Because of that if the ducting minimums are not followed the system ail short cycle on high temperature lock out reducing output temperatures.

3. Fan Motor Problem:

- Furnace blower motor running slow or below full load amp draw (**verify blower amps on motor sticker**), this may also be caused by a restriction in airflow, contrary to popular belief closing off registers will NOT increase airflow to the other registers. The fan will only move so much air as you restrict the air flow all that happens is the fan blade caveats. Which reduces the load o the motor ultimately reducing the current draw (amp load).

**Important Note:**

- Since Gas Furnaces are **not** UL Listed, they are not held to the same high temperature reset standard. In fact, most gas furnaces operated at as much as a 100 F degree higher (250 F to 300 F) reset temperature. Because of this problems with low airflows or hot air leaks are not critical.
- When blower motors start to fail due to bad bearings, the problem doesn't show its self as soon as it does on a UL Listed product. There higher reset point can also cover up overheating caused by leaking or restricted duct work.
- Do not include 2" ducts in minimum ducting requirements (*it takes 4-2' ducts to equal the air flow of one 4" duct*).

**Air Flow Specifications 4" Round Duct**

UL 2158A Rated-Max temp rating 285° F, Max Static 1.0 in.

Heat Range Configuration	Min Total CFM	Max Total CFM	Min # Supply Runs	Single 4" Round Duct			Average all 4" Round Ducts Combined		
				Max Length Supply Runs	Max 45° Bends	Max 90° Bends	Max Avg. Length of Runs	Max 45° Bends	Max 90° Bends
1800 Watt	120	300	3	25 Ft	2	1	15 Ft	6	3
3750 Watts	180	400	5	25 ft	2	1	15 Ft	10	5
5000 Watts	240	500	6	25 ft	2	1	15 Ft	12	6

**Air Flow Specifications Rectangle Duct**

28 Ga. Sheet Metal

Heat Range Configuration	Min Total CFM	Max Total CFM	Min Sq. in Supply Side Trunk line	Min # 4x8 Supply Registers	Min # 4X10 Supply Registers	Min # 2 1/4x10 Supply Registers	Min # 2 1/4x12 Supply Registers
1800 Watts	120	300	40	3	2	3	3
3750 Watts	180	400	60	4	3	5	5
5000 Watts	240	500	80	5	4	6	6

Although basic Code requirements dictate the use of an overcurrent device at the point at which a conductor received its supply, subparts (A) through (H) effectively present exceptions to this rule in the case of taps to feeders. That is, to meet the practical demands of field application, certain lengths of unprotected conductors may be used to tap energy from protected feeder conductors.

These “exceptions” to the rule for protecting conductors at their points of supply are made in the case of 10-, 25-, and 100-ft (3.0-, 7.5-, and 30.0-m) taps from a feeder, as described in 240.21, parts (B)(1), (B)(2), and (B)(4). Application of the tap rules should be made carefully to effectively minimize any sacrifice in safety. The taps are permitted without overcurrent protective devices at the point of supply.

240.21(B)(1) says that unprotected taps not over 10 ft (3.0 m) long (Fig. 240-15) may be made from feeders, provided:

1. The smaller conductors have a current rating that is not less than the combined computed loads of the circuits supplied by the tap conductors and must have ampacity of—

Not less than the rating of the “device” supplied by the tap conductors, (which formerly included the bus structure of a main lug only panelboard but given changes in 408.36, an overcurrent device is now generally required) or

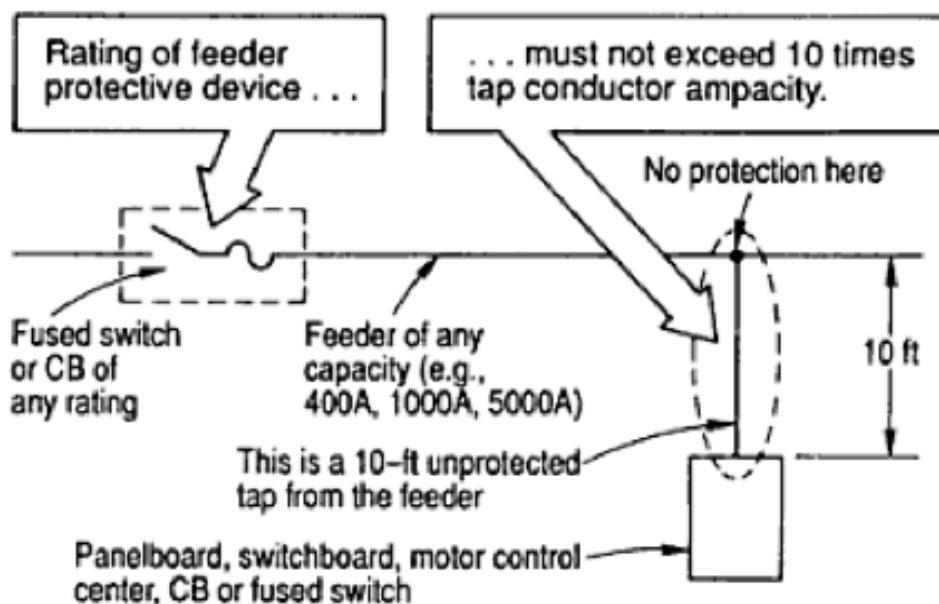

240.21(B)(1)



**SAL Product  
Warranty  
Model# CH-55 & DH18-37-50**

**CheapHeat™**

The warranty for the CheapHeat™ product is processed through an RV dealer, service centers, or OEM manufacture. Transportation of the RV to and from the Service Center and/or travel expenses of the Service Center to your location is the responsibility of the owner/user. This warranty is subject to installation as per manufacture specifications and covers the product workmanship and components for their replacement or repair as needed to return the product back to an operational state when product is used as rated. This warranty is for a period of 1 year on aftermarket installations and 2 years on OEM installations, from the date of the installation.

ALL IMPLIED WARRANTIES (INCLUDING IMPLIED WARRANTIES OF MERCHANTABILITY) ARE HEREBY LIMITED IN DURATION TO THE PERIOD FOR WHICH EACH LIMITED WARRANTY IS GIVEN. SOME STATES DO NOT ALLOW LIMITATIONS ON HOW LONG AN IMPLIED WARRANTY LASTS SO THE ABOVE LIMITATIONS MAY NOT APPLY TO YOU. THE EXPRESSED WARRANTIES MADE IN THIS WARRANTY ARE EXCLUSIVE AND MAY NOT BE ALTERED.

Other than as expressly provided for in this Agreement, RV Comfort Systems shall not be liable under any provision of this Agreement for any losses, damages, costs or expenses for any special, indirect, incidental, consequential, or punitive damages, including but not limited to loss of profit or revenue, loss of the use of equipment, cost of capital, cost of temporary equipment or services, whether based in whole or in part in contract, in tort, including negligence, strict liability, or any other theory of liability; provided, however, that damages for which a Party may be liable to another Party under another agreement will not be considered to be special, indirect, incidental, or consequential damages hereunder.

The form below must be filled out and mailed to RV Comfort Systems LLC with in 30 days of the installation (OEM with in 30 days of the RV being sold, leased, or rented to its first customer) for this warranty to be honored.

To initiate warranty cut on black line and mail to address shown at the bottom

Date Installed \_\_\_\_\_ OEM Date Sold \_\_\_\_\_

Customer Name \_\_\_\_\_ Address \_\_\_\_\_

City \_\_\_\_\_ State \_\_\_\_\_ Zip \_\_\_\_\_ Ph \_\_\_\_\_ email \_\_\_\_\_

Furnace Brand \_\_\_\_\_ Mod # \_\_\_\_\_ Serial # \_\_\_\_\_

For Ducted System: Number of Duct Runs \_\_\_\_\_ Size \_\_\_\_\_ For

Plenum System: Number of Registers \_\_\_\_\_ Size \_\_\_\_\_

Controller Serial # \_\_\_\_\_ Shore Power \_30 amp \_50 amp

Heater Serial # \_\_\_\_\_ Setting (KW) \_\_\_\_\_

Dealer/OEM: \_\_\_\_\_ Ph \_\_\_\_\_ Fax \_\_\_\_\_

Street Address \_\_\_\_\_ Mail \_\_\_\_\_

City \_\_\_\_\_ State \_\_\_\_\_ Zip \_\_\_\_\_ email \_\_\_\_\_

Tech (Print) \_\_\_\_\_ (Signature) \_\_\_\_\_

**Mail to:** RV Comfort Systems LLC. PO Box 1554 Bothell, Washington 98041